



AMPLIBAG

PRODUCT FEATURES

- Feed hopper of a capacity of **6m³**.
- Total weight 5T.
- **Big capacity** of filling (40 BIGBAG / HOUR).



Automatic scale of the product. Automatic shutting device by counter balance system.

Recovery ease by a system of mobile tray once the BIGBAG filled.

Retractable hopper.

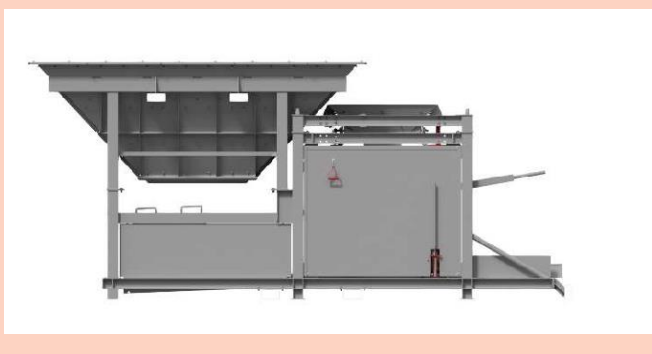

FILL IN SYSTEM OF BIGBAG

- **AMPLIBAG** is an innovative fill in system of BIGBAG. It works in **autonomus way energy-free** thanks to a patented mechanism system. It can be placed to any storage or production spot.
- **AMPLIBAG** fits to a truck to be **carried by road easily** thanks to the retractable hopper.



R. BRUNONE

CONTAINMENT • OPTIMISATION • SAFETY OF CONVEYORS

1, rue de la Cressonnière
27950 Saint-Marcel, France
Tél.: +33 (0)2 32 64 20 20
E-mail: commercial@brunone-innovation.fr



AMPLIBAG

CLEARANCE

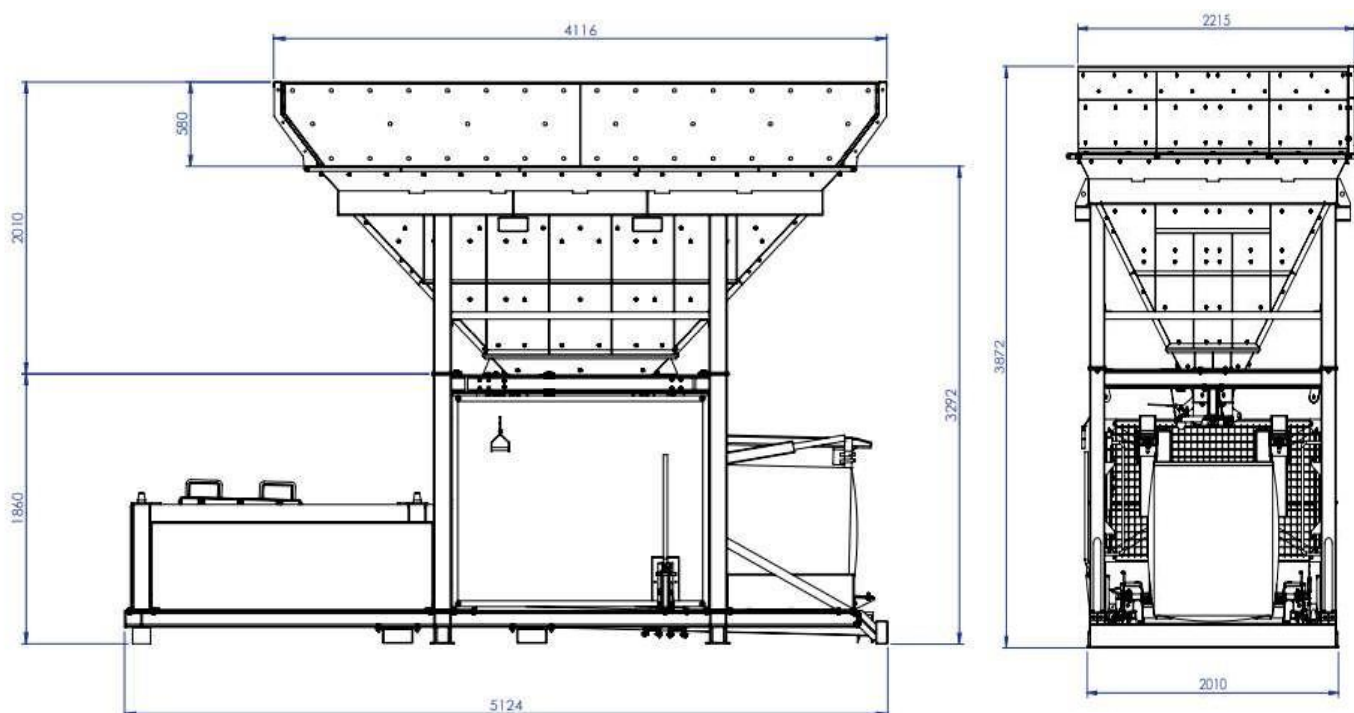

- Counter weight 1,3T
- From **400 Kg to 1700 Kg**
- Low spare parts
- **Reinforced** hopper
- Many options



R. BRUNONE

CONTAINMENT • OPTIMISATION • SAFETY OF CONVEYORS

1, rue de la Cressonnière
27950 Saint-Marcel, France
Tél.: +33 (0)2 32 64 20 20

E-mail: commercial@brunone-innovation.fr