

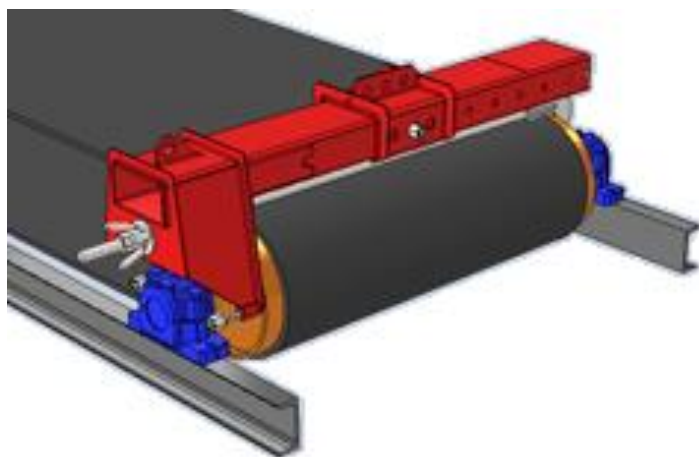

DT SPAR

Drum removal device



FAST AND EASY-TO-USE DRUM REMOVAL TOOL

- The DT SPAR is a **compact** and **innovative** system, making faster and easier any drum removal operation on a belt conveyor.
- The DT SPAR provides an easy, quick and effective way to remove a drum from a belt conveyor.
- It allows to remove the tail or head pulley using a hoist or any other lifting system, **without cutting the belt**, in complete safety for the operators.

PRODUCT FEATURES

- The DT SPAR is designed for **Ø300 to 1000mm** drums and beyond on request.
- The design of the DT SPAR ensures a **strong holding of the drum** and allows to **lift it in complete safety**.
- Maximum load for Ø300 to Ø750 drum : **1000kg**
- Maximum load for Ø750 to Ø1000 drum : **2500kg**

Compatible with all existing drums, thanks to the holding rod.

Also compatible with the new ALTEMA drums with welded-on nut (see picture below).

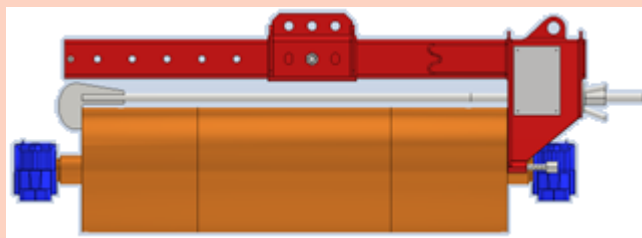

R. BRUNONE

CONTAINMENT • OPTIMISATION • SAFETY OF CONVEYORS

1, rue de la Cressonnière
27950 Saint-Marcel, France
Tél.: +33 (0)2 32 64 20 20
E-mail: commercial@brunone-innovation.fr